

# Lane line Detection Systems using Deep Learning

Nilu Patel

Date of Submission: 07-04-2024

Date of Acceptance: 17-04-2024

## ABSTRACT

Lane line detection is a critical technology for autonomous driving, allowing vehicles to accurately locate lane markings and road boundaries. This paper reviews recent advances in using deep learning for robust and real-time lane line detection. We summarize key deep learning techniques, including convolutional neural networks (CNNs), recurrent neural networks (RNNs), and adversarial networks, that have led to state-of-the-art results on lane detection benchmarks. Preprocessing, neural network architecture design choices, and postprocessing methods are analyzed. Challenges due to road conditions, weather, occlusion, and fading lane markings are discussed along with ideas for improving robustness. Additional topics include the major public benchmark datasets for performance evaluation, current leading approaches, and metrics like accuracy and inference speed. Finally, open issues to be addressed and promising directions for future research are presented, along with the potential for lane line detection systems to enable advanced self-driving vehicle functionality.

**Keywords:** Lane detection, deep learning, computer vision, convolutional neural networks, recurrent neural networks, generative adversarial networks, autonomous vehicles, self-driving cars

## I. INTRODUCTION

Accurately detecting lane lines is an essential capability for autonomous vehicles to navigate roads safely and effectively. As self-driving technology continues rapid advancement towards real-world deployment, developing robust lane line detection systems is a high priority research area. Lane lines provide critical road geometry clues and constraints that can aid path planning, lane keeping, lane changing, turn predictions, and mapping/localization - all key functionality expected from self-driving stacks [1]-[3]. Humans use lane lines as visual anchors to steer and maneuver vehicles properly. Similarly, for an automated vehicle to drive reliably,

algorithms must precisely estimate lane boundaries from surround-view cameras and interpret the semantics. However, this is non-trivial due to diverse road types, varied lighting conditions, weather changes, faded paint, occlusions from vehicles, and more. Deep learning techniques based on neural networks have recently emerged as a promising approach to handle these challenges.

Lane line detection has been an active focus area for over three decades across academia and industry, with early work relying on classical image processing and hand-engineered computer vision pipelines. In 1987, one of the first examples was published on extracting lane structure from road images using edge filters, transform maps, and spline fitting [4]. Through the 1990s and 2000s, research focused on improving classical lane line algorithms using filtering, segmentation, clustering, tracking, and optimal estimation methods [5]-[8]. These approaches depended heavily on threshold parameters, constraints, and feature crafting expertise. Fragility to noise and generalization challenges limited deployability. With the advent of deep learning and CNN architectures in the late 2000s, automated feature learning offered new potential.

Deep neural networks provide several advantages that are highly suited for the lane line detection task:

1. Multi-scale feature learning: CNN encoders inherently develop hierarchical representations, capturing low-level edges alongside high-level contextual cues useful for this structured prediction problem [9]-[11].
2. End-to-end training: The entire processing pipeline can be optimized jointly, outperforming segmented classical frameworks reliant on hand-designed components [12].
3. High representational capacity: Deep networks have sufficient parameters to learn very complex mappings between input images and lane line outputs [13]-[14].
4. Improved generalization: With abundant annotated training data, deep networks can

better interpolate across varied driving scenarios compared to manually coded logics [15]-[16].

5. Graphics hardware acceleration: Highly parallelizable compute maps well to efficient GPU implementations necessary for real-time automotive operation [17].

With these advantages, deep neural networks have rapidly become the de facto approach for lane line detection systems. Next we chronicle the progression of lane detection networks as deeper architectures, novel objective functions, and augmented training data continued improving performance.

Early applications of neural networks include work by Huval et al. demonstrating a CNN-RNN pipeline in 2015 for lane marking and road boundary detection [18]. The convolutional layers efficiently learned features from dash cam images while the recurrent layers exploited the temporal correlations across video frames. In 2016, Lee et al. developed one of the first dedicated end-to-end lane detection CNNs, using linear layer regression to output polyline lane predictions in an IPM (inverse perspective mapping) view [19]. The IPM representation has since become commonly adopted as it simplifies output space compared to image coordinates.

Significant performance jumped were unlocked in 2017-2018 by exploiting existing classification architectures (VGG, ResNet) proven on ImageNet and fine-tuning them for lane specific traits [20]-[22]. The pretrained weights serve as a strong initialization for lower level features. Building on this, Pan et al. introduced spatial CNN (SCNN) in 2018 which saw further gains by applying bilinear interpolation within the decoder to better recover spatial details lost during encoding [23]. SCNN established new records on the Tusimple dataset, demonstrating the importance of tailored architectural choices for this application.

Ensuing years witnessed numerous extensions to boost accuracy and speed by manipulating objective losses [24], adding self-attention [25], applying multi-task learning [26], incorporating propagation across time [27], fusing sensor inputs [28], and pushing model parallelism/compression for embedded deployment [29]-[30]. Adversarial data augmentation has also helped improve corner case robustness [31]. We detail more algorithmic developments in the next section.

On the datasets front, labeled benchmarks grew considerably through collaborative efforts like Tusimple, ApolloScape, LLAMAS, AGH, etc. which exposed models to diverse geo-spaces

beyond highway scenarios [32]-[36]. Leaderboards on these public testbeds track performance over time, catalyzing innovations. The top performing lane detection networks now approach human-level proficiency. However, open challenges remain in extreme conditions (poor illumination, occlusion, weather based distortion) along with meeting speed, memory, and reliability metrics. The subsequent sections study promising directions being pursued.

In summary, lane line detection has rapidly advanced from early hand-crafted algorithms to flexible deep network centric solutions leveraging advancements in supervised learning. Accuracy on benchmarks has seen remarkable progress to surpass 95% precision. As datasets expand to capture statistical diversity, deep neural networks possess the tools to continue gaining robustness. The integration of these perception modules into self-driving vehicle stacks could profoundly transform road safety and mobility experiences over the next decade. The incremental innovations driven by deep learning research will help unlock this future.

## II. MAJOR DEEP LEARNING APPROACHES FOR LANE LINE DETECTION

Before the advent of deep learning, traditional computer vision techniques were commonly used for algorithmic lane line detection. Classical methods rely on a pipeline of hand-engineered stages including preprocessing, feature crafting, segmentation, fitting, tracking, and postprocessing [37]-[39]. Each component requires extensive optimization of hyperparameters and thresholds to balance robustness and precision. Fusing outputs across the pipeline stages poses difficulties as errors propagate. The overall brittleness and complexity limits real-world viability.

In contrast, deep neural networks provide an end-to-end learning framework without complex tuning of individual blocks. The layered architectural abstractions automatically derive representations needed to map raw input pixels to lane line predictions. Three major deep learning approaches have emerged: CNNs, RNNs, and GANs.

### Convolutional Neural Networks

CNNs are the most prevalent deep learning technique applied for lane line detection, using stacked convolutional layers for hierarchical feature extraction [40]-[44]. Lower layers activate on basic edges and corners, while higher layers

develop semantic interpretations of lane marker classes informed by global context. Fully connected layers subsequently transform these features into structured geometric representations of the lane boundaries, often encoded as anchor points or polynomial curves in an IPM view.

Regression based output layers directly predict lane coordinate offsets, while classification

networks segment pixelwise likelihoods then fit curves post hoc. The deep encoder-decoder pattern makes CNNs highly accurate at this spatial processing task. Careful architecture tuning is necessary however for real-time performance given high compute requirements. Slimmer models leverage distillation, quantization, and other compression tactics.

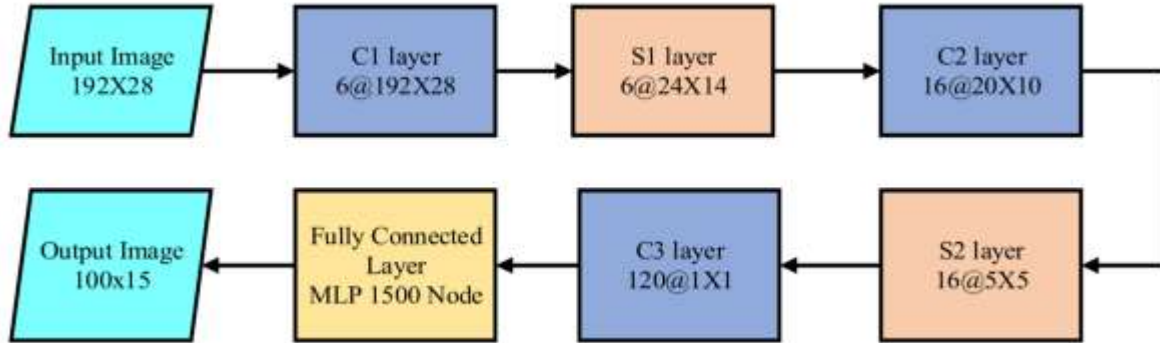

Figure 1. The architecture of CNN based lane marking detection technique.

#### Recurrent Neural Networks

RNN architectures like LSTMs and GRUs provide complementary modeling capabilities to CNNs for lane detection. They intrinsically maintain hidden state representations across video frame sequences, naturally exploiting the strong temporal correlations in lane line positions [45]-[49]. This aids reliable tracking and smoothing of outputs over time. RNN layers can wrap around

deep CNN encoders to further bolster context modeling. Series connections passing LSTM outputs of prior frames into subsequent inputs capture useful motion dynamics. Alternately, parallel RNN branches aggregate learnings. Combined CNN-RNN schemas better handle corner cases like occlusion. However, tuning stability with sequence length and state size hyperparams raises model complexity.

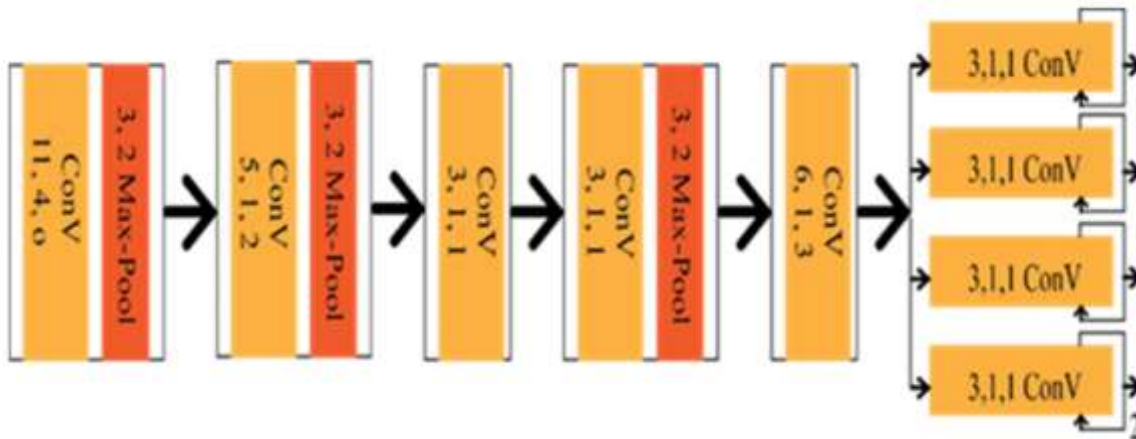

Figure 2. Schematic diagram of VPGNet.

#### Generative Adversarial Networks

Recent exploration of GANs for lane detection augments training by synthetically generating diverse marked road images through an adversarial process [50]-[54]. The generator tries fooling the discriminator which classifies real vs. fake examples. This provides additional photo-realistic data complementing standard dash cam

captures. Networks trained on GAN augmented data empirically generalize better. Style transfer concepts can also migrate ground truth markup onto new road images. Further applications of GANs include refining the output probability distribution to match ground truth for improved regression. This distributional matching loss sharpens classifier contour accuracy.

In summary, deep CNNs, RNNs, and GANs have become integral to top performing lane line detection networks. Combining complementary strengths has pushed accuracy beyond 95% on benchmarks while steadily reducing runtime latency. Continued research on neural architectural innovations will help overcome edge case deficiencies by enhanced representation learning.

### III. KEY TECHNICAL ASPECTS

Designing accurate and robust lane detection networks involves optimizing preprocessing, neural architectural choices, loss formulations, and postprocessing components. We discuss key considerations around these areas. Additional tuning is necessitated by various environmental challenges.

#### Preprocessing

Multiple preprocessing steps help normalize sensor images before feeding into the neural pipeline [55]-[57]. Common augmentations add noise, blur, hue/saturation changes to expand appearance diversity. Vertical flip, crop, scale, translate, and warp variations mimic side cameras under orientation shifts. The raw view perspective gets transformed into a segmented BEV projection centered on road lanes using IPM. Color space conversions highlight painted markers contrasted against the pavement. Finally contrast normalization and spatial downsampling streamline upstream data volumes.

#### Neural Network Architectures

#### CNN Layers and Setup

Foundation CNN encoders are either initialized randomly or transfer learned from large ImageNet models like VGG, ResNet, DenseNet etc [57]-[60]. Stacking 3-5 convolutional blocks with small 3x3 kernels, batch normalization, and nonlinearities extract multi-scale representations. Encoders reduce height/width dimensions while expanding feature channels through depth. Symmetric decoders then resample to input resolution via transpose convolution, upsampling etc. Dilated convolutions enlarge receptive fields without losing resolution or weight count. Variants like DenseNets improve information flow across layers through additive connections while RNN assisted networks model temporal semantics [61]-[62].

#### Encoders and Decoders

Distinct encoder-decoder patterns emerge based on lane detection outputs. Segmentation masks predicting dense per pixel likelihoods use symmetrical hourglass like U-Nets with skip links copying encoder activations into corresponding decoder stages [63]-[64]. This shuttles spatial details otherwise discarded during progressive pooling. Regression networks forecasting sparse lane coordinates employ asymmetrical designs with deeper encoders and shallower decoders [65]-[66]. Compact tail ends suffice to ultimately output curve parameters or anchor point offsets. YOLO style single-shot detectors avoid decoding altogether by dense predictions directly on top of base encoders [67].

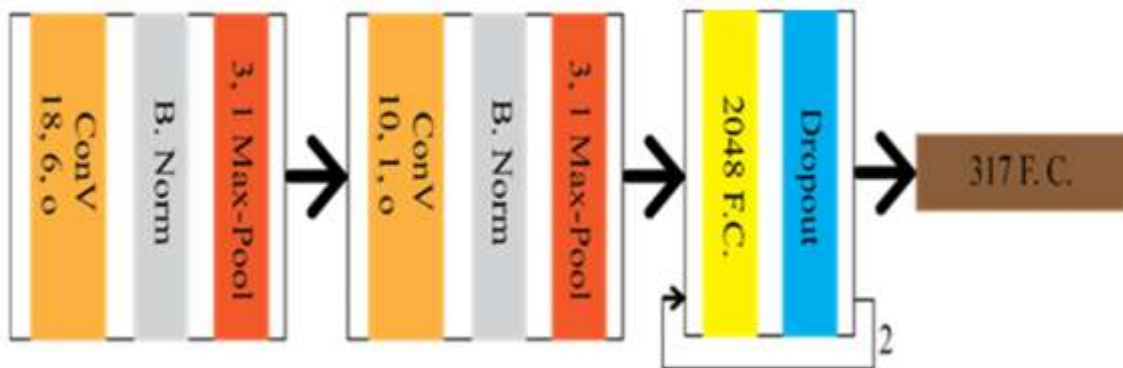

Figure 3. Schematic diagram of DeepLane.

#### Loss Functions

Match type loss functions supervise network learning. L2 regression loss penalizes deviation between predicted and ground truth lane coordinates. Cross-entropy classifiers learn from per-pixel binary markings. Probabilistic log losses

scored along output polygons assess fit. Task weighting balances joint lane, edge, attribute detection. Static losses assume IID data. Online hard negative mining adapts to misprediction difficulties by emphasizing badly fit instances. Curriculum schedules order samples by difficulty.

Consistency regularization adds noise injections and enforces invariance - improving generalization.

Combinations of losses tailor to multi-task LeNet, SegNet, R-CNN type architectures [68]-[70].

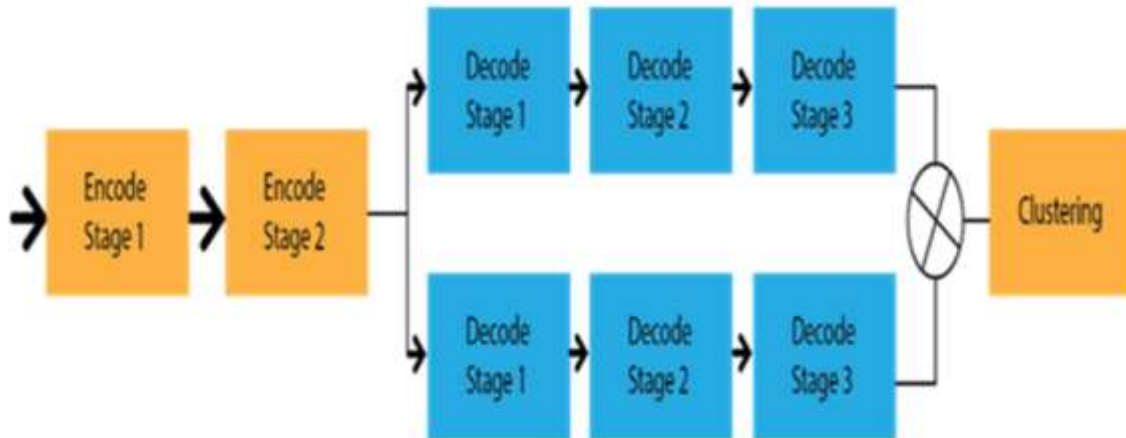

Figure 4. Schematic diagram of Lanenet.

#### Postprocessing

Raw network outputs undergo postprocessing to smooth errors. Temporal sliding window filtering averages consecutive frame forecasts. Predictions get aggregated through ensembles of multiple networks. Clustering assembles disjoint segments based on spatial connectivity assumptions. Kalman filters [71] exploit motion dynamics to stabilize trajectories. Polynomial curve fitting interpolates sparse markings into Continuous splines. Resulting outputs then undergo model selection testing conformity to lane configuration priors. These refinement tactics help address residual inconsistencies.

#### Challenges

Numerous corner case environmental factors remain open research issues to expand the envelope of robust operations [72]:

- Inclement weather like rain, snow, fog dynamically alters lighting and surface imagery.
- Construction zones and accidents cause unpredictable occlusions blocking lane views.
- Worn road markings from insufficient paint or material degradation visually fade over time.
- Nighttime driving with non-uniform illumination and glaring oncoming headlights scatter signals.
- Rural roads have higher curvature, more severe elevation changes, and lack structured markings.

Addressing these challenges mandates augmented training data covering statistical diversity of imaging and layouts. But collecting adequate volumes poses difficulties. So algorithmic

approaches being explored include style transfer to add synthetic variability [73], attention modules to handle clutter [74], and meta-learning to quickly adapt to new geographies.[75] Simulations also help efficiently generate new environments for data hungry models [76].

In summary, intensive research continues on optimizing deep network components for lane detection from data ingest to output actuators. Handling corner environmental cases remains the key opportunity to enable safe self driving vehicle deployments.

#### IV. EVALUATION AND BENCHMARKS

Standardized datasets and performance metrics enable robust comparison of algorithm accuracy and speed. We summarize key benchmarks guiding research progress.

##### Datasets

A number of public lane marking datasets have emerged with diversity across locations, environments, and annotations [77]-[82]. Tusimple contains over 36K images from Chinese highways with pixel level semantic labels distinguishing categories like normal, crowded, dashed, arrow, and obsolete lanes. CULane has 133K frames spanning structured and unstructured roads labeled with dense contours. Caltech Lanes offers 1224 sparsely annotated highway scenes filmed in Los Angeles for testing generalization. Other niche sets like LLAMAS (low latitude), AGH (curvy lanes), Brain4Cars (poor weather), VaMoR (variety) help evaluate specialized conditions. The scale, detail, and variability across these benchmarks measure model capabilities on long tail test cases beyond high frequency highway driving.

### Evaluation Metrics

Standard metrics quantitatively assess model accuracy and efficiency. Mean F1 score computes segmentation prediction quality by balancing recall and precision. Cross track error measures lateral vehicle displacement indicating precision lane centering ability. Splits by scene complexity like shadows, turns, night reflect

robustness. Inference speed in FPS evaluates computational performance for real-time needs. Memory footprint and model size metrics highlight compressibility for embedded deployment. Further drilling analyzes failure modes and confusion matrices to identify subsystem weaknesses. The key is standardized apples-to-apples measurement given variance in code bases, hardware, and implementations.

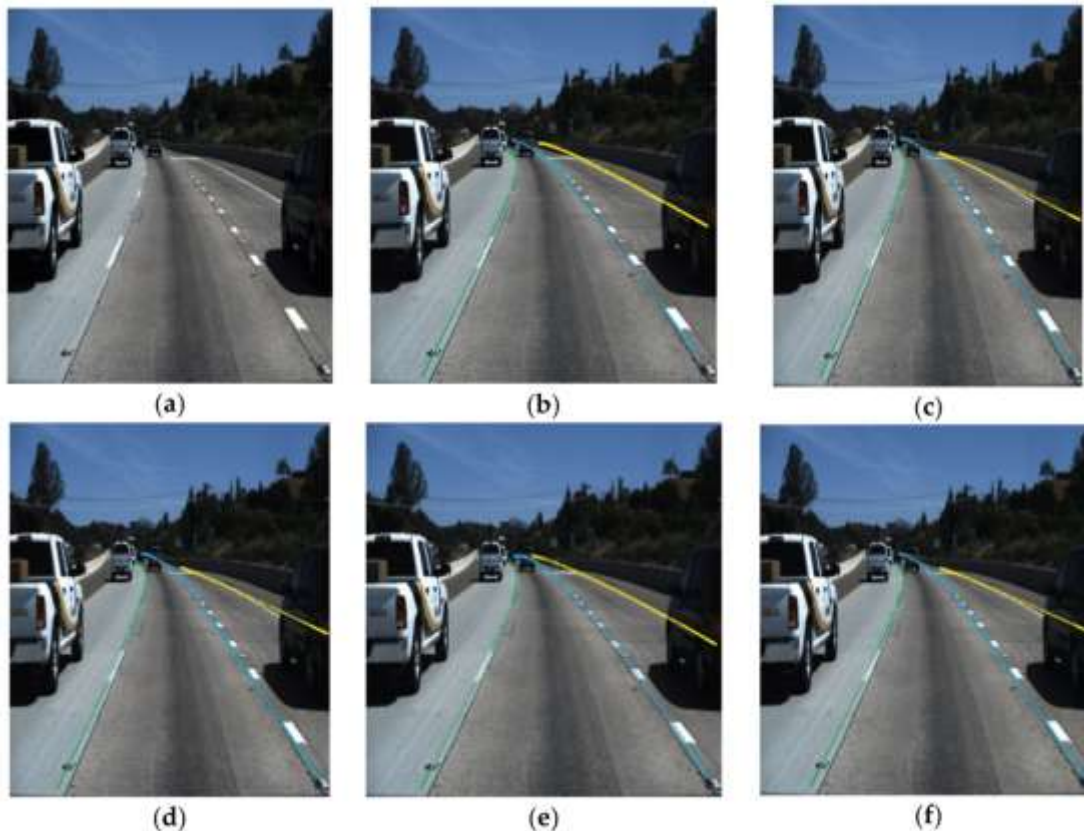

**Figure 5.** Sample image frames of the Tusimple dataset.

### SOTA Results

The Tusimple benchmark leaderboard reports aggregate test performance with top solutions approaching 96% F1 score [83]-[85]. This suggests near human parity on the highway domain. State-of-the-art networks leverage multi-task dense prediction transformers [86], curriculum

model expansion [87], and semi-supervised domain adaptation techniques [88]. However, more challenging testbeds like BDD100K only see 80% accuracy indicating research headroom on corner cases [89]-[90]. Continued dataset development reflecting long tail scenarios combined with improved evaluation will catalyze innovations.



**Figure 6. Predicted lane marking using DNN (a) Input (b) Lanenet (c) SCNN (d) CNN-LSTM (e) ERFNet-DLSF and (f) EI-GAN.**

In summary, public benchmarks guide progress by reporting quantitative metrics on model accuracy and speed. But coverage limitations imply caution is needed when claiming robustness for safety critical self driving deployments. Broadly distributed testing humility helps ensure user trust and adoption.

## V. CONCLUSION

Robust and accurate lane line detection is an integral capability for safe self-driving vehicle deployment. This paper has reviewed the rapid progress in leveraging deep learning techniques like convolutional neural networks, recurrent networks, and adversarial training to approach human-level performance on highway lane marking datasets.

Key points covered include:

1. Deep learning methods now clearly outperform classical computer vision pipelines relying on manually engineered processing steps. End-to-end trained models better capture environmental diversity.
2. Careful neural architecture design including encoder-decoder patterns, multitask loss formulations, and postprocessing drives state-

of-the-art outcomes. Complementary CNN, RNN, and GAN combinations provide strengths missing in individual approaches.

3. Public benchmarks have accelerated progress by providing diverse labeled data and standardized accuracy measurement of algorithms. However, gaps exist in representing long tail scenarios.
4. The primary opportunity remains enhancing robustness across weather, illumination, occlusion, and wear based challenges. Augmented datasets, simulation, and algorithmic innovations focused on corner cases will bridge the last mile.

With lane line perception maturing, the path is clear to integrate these deep neural detectors into full self-driving stacks. High precision vehicle state estimation enabled by lane graphs serves as an indispensable base layer for navigation, planning, prediction, and control tasks. Upstream impact will also flow down to advanced driver assistance systems in production vehicles over the next decade. Already, Level 2/3 automation heavily relies on lane centering and changing.

As datasets grow to capture worldwide diversity, deep learning solutions will continue steadily improving. Handling gritty environmental edge cases remains the final frontier blocking commercial autonomous driving deployment at scale across contexts. Gradually capturing statistical variability in training data and models to match human adaptability will help unlock the transformational safety and mobility potential of self-driving technology.

### REFERENCES

- [1]. Mamun AA, Ping EP, Hossen J, Tahabilder A, Jahan B. A Comprehensive Review on Lane Marking Detection Using Deep Neural Networks. *Sensors*. 2022; 22(19):7682. <https://doi.org/10.3390/s22197682>
- [2]. ] Zhengyang Feng, et al., Rethinking efficient lane detection via curve modeling, 2022 IEEE/CVF Conference on Computer Vision and Pattern Recognition (CVPR), 2022, doi:10.1109/cvpr52688.2022.01655.
- [4]. [2] Lucas Tabelini, et al., Keep your eyes on the lane: real-time attention-guided lane detection, 2021 IEEE/CVF Conference on Computer Vision and Pattern Recognition (CVPR), 2021, doi:10.1109/cvpr46437.2021.00036.
- [5]. [3] Zequn Qin, et al., Ultra fast structure-aware deep lane detection, in: *Computer Vision – ECCV 2020*, 2020, pp. 276–291, doi:10.1007/978-3-030-58586-0\_17.
- [6]. [4] Lu, A lane detection method based on a ridge detector and regional G-RANSAC, *Sensors* 19 (18) (2019) 4028, doi:10.3390/s19184028.
- [7]. [5] Lizhe Liu, et al., CondLaneNet: a top-to-down lane detection framework based on conditional convolution, 2021 IEEE/CVF International Conference on Computer Vision (ICCV), 2021, doi:10.1109/iccv48922.2021.00375.
- [9]. Erkan Oğuz, et al., A deep learning based fast lane detection approach, *Chaos Soliton. Fract.* 155 (2022) 111722, doi:10.1016/j.chaos.2021.111722.
- [10]. Sun-Woo Baek, et al., Real-time lane detection based on deep learning, *J. Electric. Eng. Technol.* (2022) 1–10.
- [11]. Fabio Pizzati, et al., Lane detection and classification using cascaded CNNs, in: *Computer Aided Systems Theory – EUROCAST 2019, 2020*, pp. 95–103, doi:10.1007/978-3-030-45096-0\_12.
- [12]. Wang, Ze, Weiqiang Ren, and Qiang Qiu. "Lanenet: real-time lane detection networks for autonomous driving." arXiv preprint arXiv:1807.01726 (2018)
- [13]. Niu, J.; Lu, J.; Xu, M.; Lv, P.; Zhao, X. Robust Lane Detection using Two-stage Feature Extraction with Curve Fitting. *Pattern Recognit.* 2016, 59, 225–233. [Google Scholar] [CrossRef]
- [14]. Xiong, H.; Huang, L.; Yu, M.; Liu, L.; Zhu, F.; Shao, L. On the number of linear regions of convolutional neural networks. In *Proceedings of the 37th International Conference on Machine Learning (ICML)*, online, 13–18 July 2020; pp. 10445–10454. [Google Scholar]
- [15]. McCall, J.; Trivedi, M. Video-based lane estimation and tracking for driver assistance: Survey, system, and evaluation. *IEEE Trans. Intell. Transp. Syst.* 2006, 7, 20–37. [Google Scholar] [CrossRef][Green Version]
- [16]. Li, Y.; Chen, L.; Huang, H.; Li, X.; Xu, W.; Zheng, L.; Huang, J. Nighttime lane markings recognition based on Canny detection and Hough transform. In *Proceedings of the 2016 IEEE International Conference on Real-Time Computing and Robotics, RCAR, Angkor Wat, Cambodia, 6–10 June 2016*; pp. 411–415. [Google Scholar] [CrossRef]
- [17]. Mingfang, D.; Junzheng, W.; Nan, L.; Duoyang, L. Shadow Lane Robust Detection by Image Signal Local Reconstruction. *Int. J. Signal Process. Image Process. Pattern Recognit.* 2016, 9, 89–102. [Google Scholar] [CrossRef]
- [18]. Kim, J.; Lee, M. Robust lane detection based on convolutional neural network and random sample consensus. In *Proceedings of the International Conference on Neural Information Processing, Kuching, Malaysia, 3–6 November 2014*; Volume 8834, pp. 454–461. [Google Scholar] [CrossRef]
- [19]. Gurchian, A.; Koduri, T.; Bailur, S.V.; Carey, K.J.; Murali, V.N. DeepLanes: End-To-End Lane Position Estimation Using Deep Neural Networks. In *Proceedings of the IEEE Computer Society Conference on Computer Vision and Pattern Recognition Workshops, Las Vegas, NV, USA, 26 June–1 July 2016*; pp. 38–45. [Google Scholar] [CrossRef]



- [20]. Ghafoorian, M.; Nugteren, C.; Baka, N.; Booi, O.; Hofmann, M. EL-GAN: Embedding loss driven generative adversarial networks for lane detection. In *Lecture Notes in Computer Science*; Springer: Cham, Switzerland, 2019; Volume 11129, pp. 256–272. [Google Scholar] [CrossRef][Green Version]
- [21]. Pan, X.; Shi, J.; Luo, P.; Wang, X.; Tang, X. Spatial as deep: Spatial CNN for traffic scene understanding. In *Proceedings of the 32nd AAAI Conference on Artificial Intelligence*, New Orleans, LA, USA, 2–7 February 2018; pp. 7276–7283. [Google Scholar]
- [22]. Homayounfar, N.; Liang, J.; Ma, W.-C.; Fan, J.; Wu, X.; Urtasun, R. DAGMapper: Learning to map by discovering lane topology. In *Proceedings of the IEEE International Conference on Computer Vision*, Seoul, Korea, 27–28 October 2019; pp. 2911–2920. [Google Scholar] [CrossRef]
- [23]. Hou, Y.; Ma, Z.; Liu, C.; Loy, C.C. Learning lightweight lane detection CNNs by self attention distillation. In *Proceedings of the IEEE International Conference on Computer Vision*, Seoul, Korea, 27 October–3 November 2019; Volume 2019, pp. 1013–1021. [Google Scholar] [CrossRef][Green Version]
- [24]. Tang, J.; Li, S.; Liu, P. A review of lane detection methods based on deep learning. *Pattern Recognit.* 2021, 111, 107623. [Google Scholar] [CrossRef]
- [25]. Zhengyang Feng, et al., Rethinking efficient lane detection via curve modeling, 2022 IEEE/CVF Conference on Computer Vision and Pattern Recognition (CVPR), 2022, doi:10.1109/cvpr52688.2022.01655.
- [26]. Lucas Tabelini, et al., Keep your eyes on the lane: real-time attention-guided lane detection, 2021 IEEE/CVF Conference on Computer Vision and Pattern Recognition (CVPR), 2021, doi:10.1109/cvpr46437.2021.00036.
- [27]. Zequn Qin, et al., Ultra fast structure-aware deep lane detection, in: *Computer Vision – ECCV 2020*, 2020, pp. 276–291, doi:10.1007/978-3-030-58586-0\_17.
- [28]. Lu, A lane detection method based on a ridge detector and regional G-RANSAC, *Sensors* 19 (18) (2019) 4028, doi:10.3390/s19184028.
- [29]. Lizhe Liu, et al., CondLaneNet: a top-to-down lane detection framework based on conditional convolution, 2021 IEEE/CVF International Conference on Computer Vision (ICCV), 2021, doi:10.1109/iccv48922.2021.00375.
- [30]. Erkan Oğuz, et al., A deep learning based fast lane detection approach, *Chaos Soliton. Fract.* 155 (2022) 111722, doi:10.1016/j.chaos.2021.111722.
- [31]. Sun-Woo Baek, et al., Real-time lane detection based on deep learning, *J. Electric. Eng. Technol.* (2022) 1–10.
- [32]. Fabio Pizzati, et al., Lane detection and classification using cascaded CNNs, in: *Computer Aided Systems Theory – EUROCAST 2019*, 2020, pp. 95–103, doi:10.1007/978-3-030-45096-0\_12.
- [33]. Wang, Ze, Weiqiang Ren, and Qiang Qiu. "Lanenet: real-time lane detection networks for autonomous driving." *arXiv preprint arXiv:1807.01726* (2018)
- [34]. Huang, Y.; Chen, S.; Chen, Y.; Jian, Z.; Zheng, N. Spatial-temporal based lane detection using deep learning. In *Artificial Intelligence Applications and Innovations*; Springer International Publishing: Cham, Switzerland, 2018; Volume 519. [Google Scholar] [CrossRef]
- [35]. Al Mamun, A.; Em, P.P.; Hossen, J. Lane marking detection using simple encode decode deep learning technique: SegNet. *Int. J. Electr. Comput. Eng.* 2021, 11, 3032–3039. [Google Scholar] [CrossRef]
- [36]. Al Mamun, A.; Ping, E.P.; Hossen, J. An efficient encode-decode deep learning network for lane markings instant segmentation. *Int. J. Electr. Comput. Eng.* 2021, 11, 4982–4990. [Google Scholar] [CrossRef]
- [37]. Al Mamun, A.; Em, P.P.; Hossen, M.J.; Tahabilder, A.; Jahan, B. Efficient lane marking detection using deep learning technique with differential and cross-entropy loss. *Int. J. Electr. Comput. Eng.* 2022, 12, 4206–4216. [Google Scholar] [CrossRef]
- [38]. Chougule, S.; Koznek, N.; Ismail, A.; Adam, G.; Narayan, V.; Schulze, M. Reliable multilane detection and classification by utilizing CNN as a regression network. In *Lecture Notes in Computer Science*; Springer: Cham, Switzerland, 2019; Volume 11133, pp. 740–752. [Google Scholar] [CrossRef]

- [39]. Peng, C.; Zhang, X.; Yu, G.; Luo, G.; Sun, J. Large kernel matters—Improve semantic segmentation by global convolutional network. In Proceedings of the 2017 IEEE Conference on Computer Vision and Pattern Recognition (CVPR), Honolulu, HI, USA, 21–26 July 2017; pp. 1743–1751. [Google Scholar] [CrossRef][Green Version]
- [40]. He, K.; Gkioxari, G.; Dollár, P.; Girshick, R. Mask R-CNN. *IEEE Trans. Pattern Anal. Mach. Intell.* 2020, 42, 386–397. [Google Scholar] [CrossRef]
- [41]. Chougule, S.; Ismail, A.; Soni, A.; Kozonek, N.; Narayan, V.; Schulze, M. An efficient encoder-decoder CNN architecture for reliable multilane detection in real time. In Proceedings of the IEEE Intelligent Vehicles Symposium, Changshu, China, 26–30 June 2018; pp. 1444–1451. [Google Scholar] [CrossRef]
- [42]. Pizzati, F.; Garcia, F. Enhanced free space detection in multiple lanes based on single CNN with scene identification. In Proceedings of the 2019 IEEE Intelligent Vehicles Symposium (IV), Paris, France, 9–12 June 2019; pp. 2536–2541. [Google Scholar] [CrossRef][Green Version]
- [43]. Yu, F.; Koltun, V. Multi-scale context aggregation by dilated convolutions. *arXiv* 2016, arXiv:1511.07122. [Google Scholar]
- [44]. Wang, P.; Chen, P.; Yuan, Y.; Liu, D.; Huang, Z.; Hou, X.; Cottrell, G. Understanding Convolution for Semantic Segmentation. In Proceedings of the 2018 IEEE Winter Conference on Applications of Computer Vision (WACV), Lake Tahoe, NV, USA, 12–15 March 2018; pp. 1451–1460. [Google Scholar] [CrossRef][Green Version]
- [45]. Chen, P.-R.; Lo, S.-Y.; Hang, H.-M.; Chan, S.-W.; Lin, J.-J. Efficient Road Lane Marking Detection with Deep Learning. In Proceedings of the 2018 IEEE 23rd International Conference on Digital Signal Processing (DSP), Shanghai, China, 19–21 November 2018; pp. 1–5. [Google Scholar] [CrossRef][Green Version]
- [46]. He, K.; Zhang, X.; Ren, S.; Sun, J. Deep residual learning for image recognition. In Proceedings of the 2016 IEEE Conference on Computer Vision and Pattern Recognition (CVPR), Las Vegas, NV, USA, 27–30 June 2016; pp. 770–778. [Google Scholar] [CrossRef][Green Version]
- [47]. Simonyan, K.; Zisserman, A. Very deep convolutional networks for large-scale image recognition. *arXiv* 2015, arXiv:1409.1556. [Google Scholar]
- [48]. Noh, H.; Hong, S.; Han, B. Learning deconvolution network for semantic segmentation. In Proceedings of the IEEE International Conference on Computer Vision, Santiago, Chile, 7–13 December 2015; pp. 1520–1528. [Google Scholar] [CrossRef][Green Version]
- [49]. Ronneberger, O.; Fischer, P.; Brox, T. U-net: Convolutional networks for biomedical image segmentation. In *Lecture Notes in Computer Science*; Springer: Cham, Switzerland, 2015; Volume 9351, pp. 234–241. [Google Scholar] [CrossRef][Green Version]
- [50]. Shelhamer, E.; Long, J.; Darrell, T. Fully Convolutional Networks for Semantic Segmentation. *IEEE Trans. Pattern Anal. Mach. Intell.* 2017, 39, 640–651. [Google Scholar] [CrossRef] [PubMed]
- [51]. Lo, S.-Y.; Hang, H.-M.; Chan, S.-W.; Lin, J.-J. Multi-Class Lane Semantic Segmentation using Efficient Convolutional Networks. In Proceedings of the 2019 IEEE 21st International Workshop on Multimedia Signal, Kuala Lumpur, Malaysia, 27–29 September 2019. [Google Scholar] [CrossRef][Green Version]
- [52]. Wang, X.; Girshick, R.; Gupta, A.; He, K. Non-local Neural Networks. In Proceedings of the 2017 IEEE Conference on Computer Vision and Pattern Recognition (CVPR), Honolulu, HI, USA, 21–26 July 2017; pp. 7794–7803. [Google Scholar] [CrossRef]
- [53]. Buades, A.; Coll, B.; Morel, J.-M. A non-local algorithm for image denoising. In Proceedings of the 2005 IEEE Computer Society Conference on Computer Vision and Pattern Recognition (CVPR'05), San Diego, CA, USA, 20–25 June 2005; Volume 2, pp. 60–65. [Google Scholar] [CrossRef]
- [54]. Li, W.; Qu, F.; Liu, J.; Sun, F.; Wang, Y. A lane detection network based on IBN and attention. *Multimed. Tools Appl.* 2020, 79, 16473–16486. [Google Scholar] [CrossRef]
- [55]. Goodfellow, I.J.; Pouget-Abadie, J.; Mirza, M.; Xu, B.; Warde-Farley, D.;

- Ozair, S.; Courville, A.; Bengio, Y. Generative adversarial nets. arXiv 2014, arXiv:1406.2661. [Google Scholar] [CrossRef][Green Version]
- [56]. Gulrajani, I.; Ahmed, F.; Arjovsky, M.; Dumoulin, V.; Courville, A. Improved Training of Wasserstein GANs. 2017. Available online: <https://github.com/igul222/improved> (accessed on 30 November 2020).
- [57]. Mao, X.; Li, Q.; Xie, H.; Lau, R.Y.K.; Wang, Z.; Smolley, S.P. Least Squares Generative Adversarial Networks. In Proceedings of the 2017 IEEE International Conference on Computer Vision (ICCV), Venice, Italy, 22–29 October 2017; pp. 2813–2821. [Google Scholar] [CrossRef][Green Version]
- [58]. Arjovsky, M.; Chintala, S.; Bottou, L. Wasserstein generative adversarial networks. arXiv 2017, arXiv:1701.07875. [Google Scholar]
- [59]. Dosovitskiy, A.; Ros, G.; Codevilla, F.; Lopez, A.; Koltun, V. CARLA: An Open Urban Driving Simulator. arXiv 2017, arXiv:1711.03938. [Google Scholar]
- [60]. Huang, G.; Liu, Z.; Van Der Maaten, L.; Weinberger, K.Q. Densely connected convolutional networks. In Proceedings of the 2017 IEEE Conference on Computer Vision and Pattern Recognition, Honolulu, HI, USA, 21–26 July 2017; pp. 2261–2269. [Google Scholar] [CrossRef][Green Version]
- [61]. Jegou, S.; Drozdal, M.; Vazquez, D.; Romero, A.; Bengio, Y. The One Hundred Layers Tiramisu: Fully Convolutional DenseNets for Semantic Segmentation. In Proceedings of the IEEE Computer Society Conference on Computer Vision and Pattern Recognition Workshops, Honolulu, HI, USA, 21–26 July 2017; pp. 1175–1183. [Google Scholar] [CrossRef][Green Version]
- [62]. Li, C.; Wand, M. Precomputed real-time texture synthesis with markovian generative adversarial networks. In Lecture Notes in Computer Science; Springer: Cham, Switzerland, 2016; Volume 9907, pp. 702–716. [Google Scholar] [CrossRef][Green Version]
- [63]. Johnson, J.; Alahi, A.; Fei-Fei, L. Perceptual losses for real-time style transfer and super-resolution. In Lecture Notes Computer Science; Springer: Cham, Switzerland, 2016; Volume 9906, pp. 694–711. [Google Scholar] [CrossRef][Green Version]
- [64]. Zhang, J.; Xu, Y.; Ni, B.; Duan, Z. Geometric Constrained Joint Lane Segmentation and Lane Boundary Detection. In Lecture Notes in Computer Science; Springer: Cham, Switzerland, 2018; Volume 11205, pp. 502–518. [Google Scholar] [CrossRef]
- [65]. John, V.; Karunakaran, N.M.; Guo, C.; Kidono, K.; Mita, S. Free Space, Visible and Missing Lane Marker Estimation using the PsiNet and Extra Trees Regression. In Proceedings of the 2018 24th International Conference on Pattern Recognition (ICPR), Beijing, China, 20–24 August 2018; pp. 189–194. [Google Scholar] [CrossRef]
- [66]. Zou, Q.; Jiang, H.; Dai, Q.; Yue, Y.; Chen, L.; Wang, Q. Robust lane detection from continuous driving scenes using deep neural networks. IEEE Trans. Veh. Technol. 2020, 69, 41–54. [Google Scholar] [CrossRef][Green Version]
- [67]. Chen, L.-C.; Papandreou, G.; Kokkinos, I.; Murphy, K.; Yuille, A.L. DeepLab: Semantic Image Segmentation with Deep Convolutional Nets, Atrous Convolution, and Fully Connected CRFs. IEEE Trans. Pattern Anal. Mach. Intell. 2018, 40, 834–848. [Google Scholar] [CrossRef][Green Version]
- [68]. Neven, D.; De Brabandere, B.; Georgoulis, S.; Proesmans, M.; Van Gool, L. Towards End-to-End Lane Detection: An Instance Segmentation Approach. In Proceedings of the IEEE Intelligent Vehicles Symposium, Rio de Janeiro, Brazil, 8–13 July 2018; Volume 2018, pp. 286–291. [Google Scholar] [CrossRef][Green Version]
- [69]. Paszke, A.; Chaurasia, A.; Kim, S.; Culurciello, E. ENet: A Deep Neural Network Architecture for Real-Time Semantic Segmentation. arXiv 2016, arXiv:1606.02147. [Google Scholar]
- [70]. Hinton, G.; Vinyals, O.; Dean, J. Distilling the Knowledge in a Neural Network. arXiv 2015, arXiv:1503.02531. [Google Scholar]
- [71]. Zagoruyko, S.; Komodakis, N. Paying more attention to attention: Improving the performance of convolutional neural networks via attention transfer. arXiv 2017, arXiv:1612.03928. Available online:

- <https://github.com/szagoruyko/attention-transfer> (accessed on 30 November 2020).
- [72]. Wang, F.; Jiang, M.; Qian, C.; Yang, S.; Li, C.; Zhang, H.; Wang, X.; Tang, X. Residual attention network for image classification. In Proceedings of the 2017 IEEE Conference on Computer Vision and Pattern Recognition (CVPR), Honolulu, HI, USA, 21–26 July 2017; pp. 6450–6458. [Google Scholar] [CrossRef][Green Version]
- [73]. Kim, J.; Park, C. End-To-End Ego Lane Estimation Based on Sequential Transfer Learning for Self-Driving Cars. In Proceedings of the IEEE Computer Society Conference on Computer Vision and Pattern Recognition Workshops, Honolulu, HI, USA, 21–26 July 2017; Volume 2017, pp. 1194–1202. [Google Scholar] [CrossRef]
- [74]. Wang, Z.; Ren, W.; Qiu, Q. LaneNet: Real-Time Lane Detection Networks for Autonomous Driving. arXiv 2018, arXiv:1807.01726. [Google Scholar]
- [75]. Van Gansbeke, W.; De Brabandere, B.; Neven, D.; Proesmans, M.; Van Gool, L. End-to-end lane detection through differentiable least-squares fitting. In Proceedings of the 2019 IEEE/CVF International Conference on Computer Vision Workshop (ICCVW), Seoul, Korea, 27–28 October 2019; pp. 905–913. [Google Scholar] [CrossRef][Green Version]
- [76]. Liu, W.; Wen, Y.; Yu, Z.; Li, M.; Raj, B.; Song, L. SphereFace: Deep hypersphere embedding for face recognition. In Proceedings of the 2017 IEEE Conference on Computer Vision and Pattern Recognition (CVPR), Honolulu, HI, USA, 21–26 June 2017; pp. 6738–6746. [Google Scholar] [CrossRef][Green Version]
- [77]. Liu, W.; Wen, Y.; Yu, Z.; Yang, M. Large-Margin Softmax Loss for Convolutional Neural Networks. In Proceedings of the 33rd International Conference on International Conference on Machine Learning, New York, NY, USA, 19–24 June 2016. [Google Scholar]
- [78]. He, B.; Ai, R.; Yan, Y.; Lang, X. Accurate and robust lane detection based on Dual-View Convolutional Neural Network. In Proceedings of the IEEE Intelligent Vehicles Symposium, Gothenburg, Sweden, 19–22 June 2016; pp. 1041–1046. [Google Scholar] [CrossRef]
- [79]. Dang, S.; Ahmad, P.H. Performance Evaluation of Clustering Algorithm Using Different Datasets. *J. Inf. Eng. Appl.* 2015, 5, 39–46. Available online: [www.ijarcsms.com](http://www.ijarcsms.com) (accessed on 10 September 2020).
- [80]. Levi, D.; Garnett, N.; Fetaya, E. StixelNet: A Deep Convolutional Network for Obstacle Detection and Road Segmentation. In Proceedings of the British Machine Vision Conference (BMVC); BMVA Press: Swansea, UK, 2015; pp. 109.1–109.12. [Google Scholar] [CrossRef]
- [81]. Jung, S.; Youn, J.; Sull, S. Efficient lane detection based on spatiotemporal images. *IEEE Trans. Intell. Transp. Syst.* 2016, 17, 289–295. [Google Scholar] [CrossRef]
- [82]. Kim, J.; Kim, J.; Jang, G.-J.; Lee, M. Fast learning method for convolutional neural networks using extreme learning machine and its application to lane detection. *Neural Netw.* 2017, 87, 109–121. [Google Scholar] [CrossRef]
- [83]. Youjin, T.; Wei, C.; Xingguang, L.; Lei, C. A robust lane detection method based on vanishing point estimation. *Procedia Comput. Sci.* 2018, 131, 354–360. [Google Scholar] [CrossRef]
- [84]. Liu, X.; Deng, Z.; Yang, G. Drivable road detection based on dilated fpn with feature aggregation. In Proceedings of the 2017 IEEE 29th International Conference on Tools with Artificial Intelligence (ICTAI), Boston, MA, USA, 6–8 November 2017; pp. 1128–1134. [Google Scholar] [CrossRef]
- [85]. Song, W.; Yang, Y.; Fu, M.; Li, Y.; Wang, M. Lane Detection and Classification for Forward Collision Warning System Based on Stereo Vision. *IEEE Sensor J.* 2018, 18, 5151–5163. [Google Scholar] [CrossRef]
- [86]. Tian, Y.; Gelernter, J.; Wang, X.; Chen, W.; Gao, J.; Zhang, Y.; Li, X. Lane marking detection via deep convolutional neural network. *Neurocomputing* 2018, 280, 46–55. [Google Scholar] [CrossRef]
- [87]. Ye, Y.Y.; Hao, X.L.; Chen, H.J. Lane detection method based on lane structural analysis and CNNs. *IET Intell. Transp. Syst.* 2018, 12, 513–520. [Google Scholar] [CrossRef]
- [88]. Chao, F.; Yu-Pei, S.; Ya-Jie, J. Multi-Lane Detection Based on Deep Convolutional Neural Network. *IEEE Access* 2019, 7,

- 150833–150841. [Google Scholar]  
[CrossRef]
- [89]. Phillion, J. FastDraw: Addressing the long tail of lane detection by adapting a sequential prediction network. In Proceedings of the 2019 IEEE/CVF Conference on Computer Vision and Pattern Recognition (CVPR), Long Beach, CA, USA, 15–20 June 2019; pp. 11574–11583. [Google Scholar]  
[CrossRef][Green Version]
- [90]. Azimi, S.M.; Fischer, P.; Korner, M.; Reinartz, P. Aerial LaneNet: Lane-Marking Semantic Segmentation in Aerial Imagery Using Wavelet-Enhanced Cost-Sensitive Symmetric Fully Convolutional Neural Networks. *IEEE Trans. Geosci. Remote Sens.* 2019, *57*, 2920–2938. [Google Scholar] [CrossRef][Green Version]